



**EXTREME ENVIRONMENT EQUIPMENT TECHNOLOGY**

**DATA SHEET**  
**RAYLITE 006AC or RAYLITE 006DC**  
**Underwater Quartz Halogen or LED Light**



Mechanical

Material: 6061-T6 Black chromic Anodised  
Dimensions: Length: 80mm x Diameter: 60mm Ø  
Weight In Air: 0.3Kg  
Weight In Water: 0.15Kg  
Depth Rating: 1500 MSW  
Operating Temperature: -10°C to 50°C

Optical

Pressure lens: Sodium Toughend Glass

LED

Typical luminous Flux: 1800 Lumens  
Typical Luminous at 1m: 700 lux  
Typical Colour Temperature: 6600 Kelvin (options available)  
Beam Angle: 86°

Quartz Halogen

Bulb Type: E11 120Vac/150W Maximum

Electrical:

Underwater Connector: Standard XSG-3-MP ( Options available)  
Power Requirements: LED: 20 to 40Vdc 700mA Constant Current  
Quartz Halogen: 120Vac@ 1.25A

# RAYLITE 006

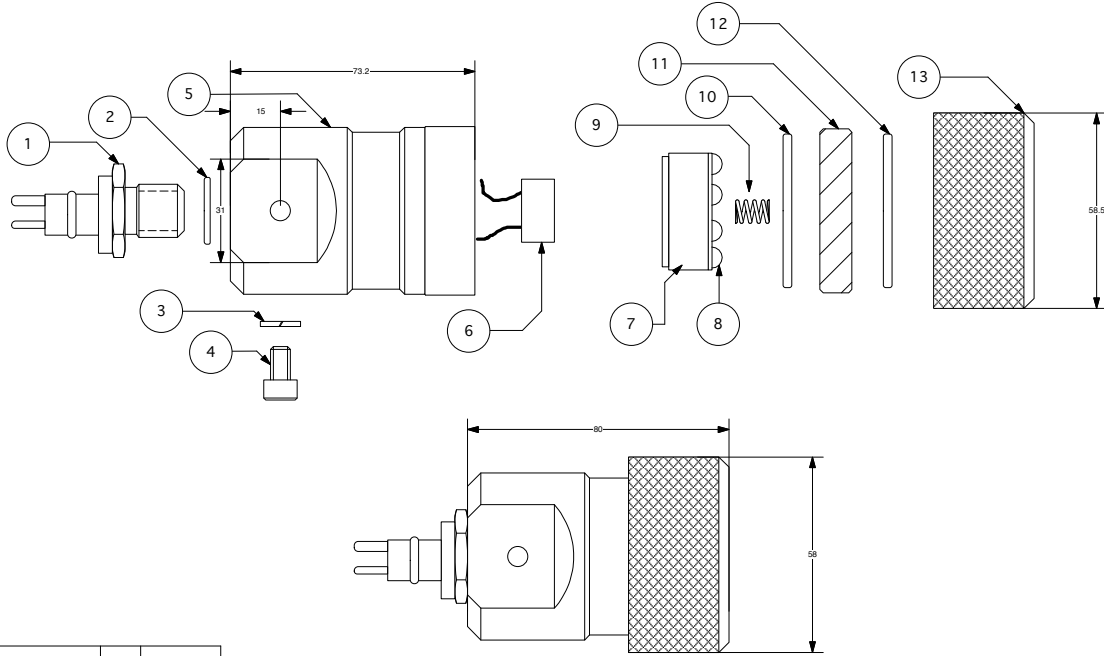

ITEM NO.	PARTS DESCRIPTION	QTY	PART NO.
1	SUBSEA BULKHEAD CONNECTOR	1	
2	BULKHEAD CONNECTOR O-RING	1	
3	M6 STAINLESS STEEL SPRING WASHER	1	
4	M6 X 1.0 STAINLESS STEEL GRAB SCREWS	1	
5	6061-T6 BLACK ANODISED PRESSURE BARREL	1	
6	BRIDGE/LED CONTROLLER	1	
7	LED HEAT SINK	1	
8	6 X CREE LED ENGINE	1	
9	RETAINER SPRING	1	
10	LENS O-RING	1	
11	TOUGHENED GLASS WINDOW (1000M)	1	
12	LOCKING COLLAR O-RING	1	
13	6061-T6 BLACK ANODISED LOCKING COLLAR	1	

THIS DRAWING AND THE SPECIFICATIONS, HEREIN, ARE THE PROPERTY OF RAYTECH SERVICES PTY LTD AND SHALL NOT BE REPRODUCED, COPIED OR USED IN WHOLE OR IN PART AS THE BASIS FOR THE MANUFACTURE OR SALE OF ITEMS WITHOUT A WRITTEN PERMISSION FROM RAYTECH SERVICES PTY LTD

© COPYRIGHT 2005 RAYTECH SERVICES PTY LTD

<p>UNLESS OTHERWISE SPECIFIED DIMENSIONS ARE IN MILLIMETERS TOLERANCE ON ANGLE ±.5° 0 PL ±.5 1PL ±.05 INTERPRET DIM AND TOL PER ASME Y14.5M-1994</p>	DESIGNED BY WDR
	DRAWN BY WDR
	CHECKED BY R.HLOBIL
	APPROVED BY
FIRST ANGLE PROJECTION	OTHER APPROVALS N/R
	CAD FILE NAME RAYLite_6

<p><b>RAYTECH SERVICES PTY LTD</b> 8b SPARKS RD, HENDERSON WA 6166 Phone: 089 437 3022 Facsimile: 089 437 3425 E-mail: raytech@raynertech.com.au</p>			
<p>TITLE <b>UNDERWATER LED LIGHT DATA SHEET Raylite 003 EXPLODED VIEW</b></p>			
SIZE A3	CAGE CODE Cge Cd	DRAWING NO. 1	REV 1
SCALE 1:1	EST. WGT N/A	SHEET 1 OF 1	