



EXTREME ENVIRONMENT EQUIPMENT TECHNOLOGY

DATA SHEET
MANUAL CABLE WINCH



Construction:	Aluminium Box Section Fully Welded.
Finish:	Black Anodised.
Min. Cable Bend Radius:	220mm
Max. Cable Capacity - 10ØmmCable:	200m
Slipring:	Moog 12 Pass 2A @ 200Vdc IP 68
Connector Rotating J-Box:	14Pin Mil-spec Socket Panel Mount
Connector Stationary J-Box:	14Pin Mil-spec Plug Panel Mount
Support Bearings:	Pillow self-aligning Sealed, Hollow Stainless shaft
Drive Mechanism:	2: 1 Crank Handle.
Drum Brake:	Spring Loaded Location Pin.
Cable Drum Diameter:	Barrel: 220 Ø mm x 360 mm; Ends: 500 Ø mm

MANUAL CABLE REELER

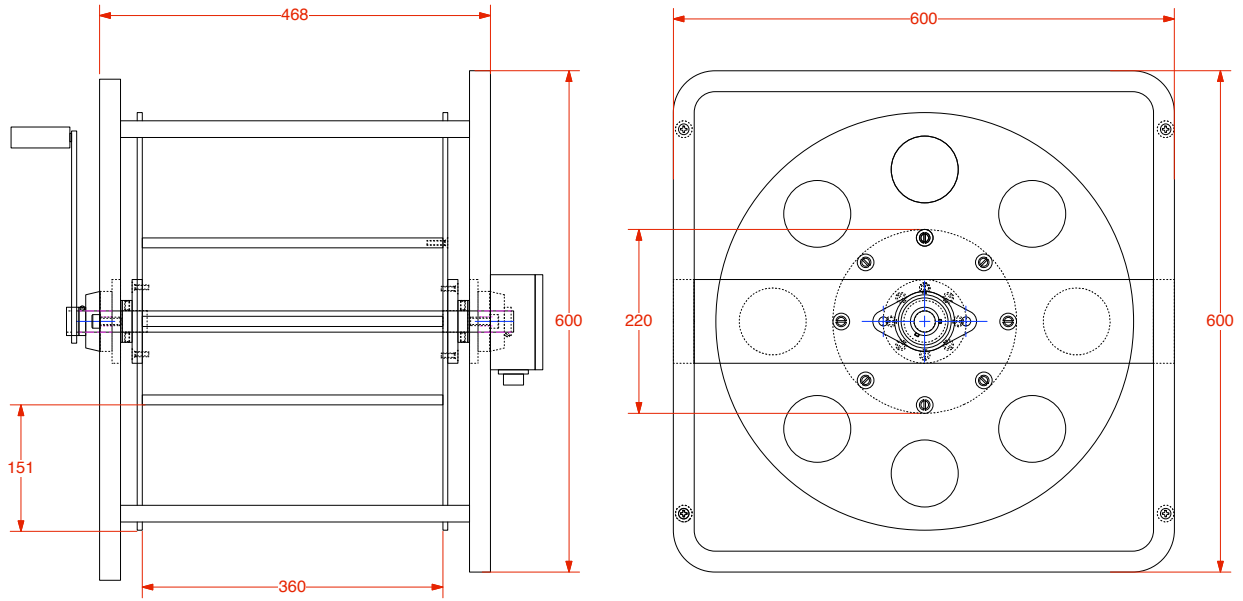

THIS DRAWING AND THE SPECIFICATIONS, HEREIN, ARE THE PROPERTY OF RAYTECH SERVICES PTY LTD AND SHALL NOT BE REPRODUCED, COPIED OR USED IN WHOLE OR IN PART AS THE BASIS FOR THE MANUFACTURE OR SALE OF ITEMS WITHOUT A WRITTEN PERMISSION FROM RAYTECH SERVICES PTY LTD
 © COPYRIGHT 2005 RAYTECH SERVICES PTY LTD

DESIGNED BY WDR DRAWN BY WDR CHECKED BY R.HLOBIL APPROVED BY	RAYTECH SERVICES PTY LTD 8b SPARKS RD, HENDERSON WA 6166 Phone: 089 437 3022 Fax: 089 437 3425 E-mail: raytech@raymartechnologies.com.au TITLE RAYTECH SERVICES PTY LTD CABLE REELER GA																
OTHER APPROVALS CAD FILE NAME CABLREELER_1	<table border="1" style="width: 100%; border-collapse: collapse;"> <tr> <td style="font-size: small;">SIZE</td> <td style="font-size: small;">CAGE CODE</td> <td style="font-size: small;">DRAWINGS NO.</td> <td style="font-size: small;">REV</td> </tr> <tr> <td style="text-align: center;">A3</td> <td style="text-align: center;">Cge Cd</td> <td style="text-align: center;">1</td> <td style="text-align: center;">1</td> </tr> <tr> <td style="font-size: x-small;">SCALE</td> <td style="font-size: x-small;">EST. WGT</td> <td style="font-size: x-small;">SHEET</td> <td style="font-size: x-small;">OF</td> </tr> <tr> <td style="text-align: center;">1:4</td> <td></td> <td style="text-align: center;">1</td> <td style="text-align: center;">3</td> </tr> </table>	SIZE	CAGE CODE	DRAWINGS NO.	REV	A3	Cge Cd	1	1	SCALE	EST. WGT	SHEET	OF	1:4		1	3
SIZE	CAGE CODE	DRAWINGS NO.	REV														
A3	Cge Cd	1	1														
SCALE	EST. WGT	SHEET	OF														
1:4		1	3														